

Siphon design Flowstar S
 Finition: **Chrome** N° Art.: **52105000**



Description

Caractéristiques

- plage de réglage: 60 - 165 mm
- distance du mur 330 mm
- piège à odeurs - la hauteur de l'eau de refoulement est de 75 mm
- dimension du raccordement d'entrée: G 1 1/4"
- dimensions du raccordement de sortie: DN32
- acc. contrôlé par un tiers. DIN EN 274-3

Prix du design



Photo du produit



Plan coté

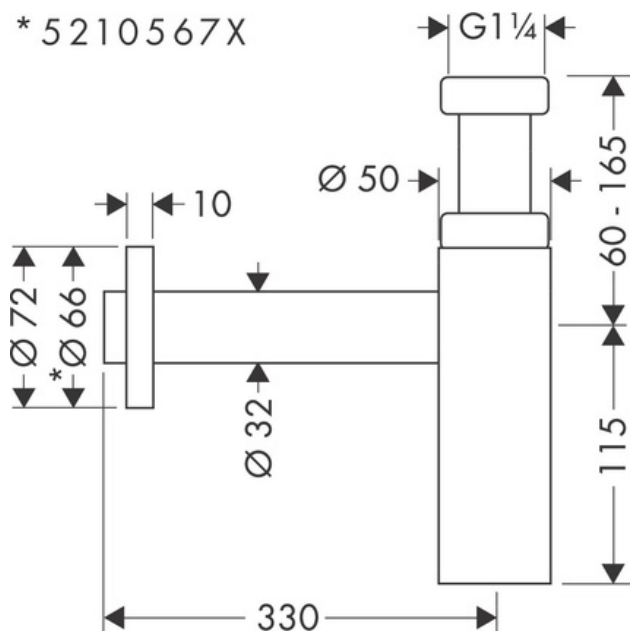

Siphon design Flowstar S
 Finition: **Chrome** N° Art.: **52105000**



Vue éclatée

Annéedeconstruction: >03/04

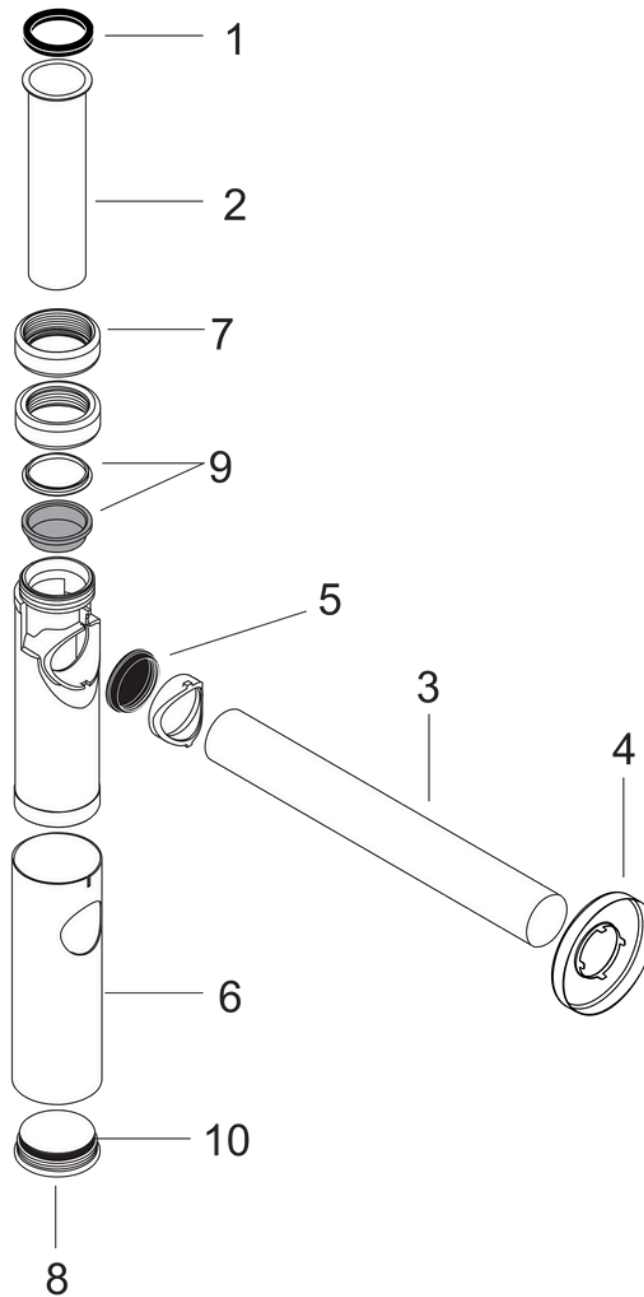

Siphon design Flowstar S
 Finition: **Chrome** N° Art.: **52105000**



Liste des pièces détachées

Année de construction: >03/04

Pos.	Description	N° Art.	GP	UE
1 2	garniture 1¼"	53971000	-	1
3 4	tube coulissant 1¼" 150 mm	96420000	-	1
5 6	tube de sortie 1¼" 500 mm	53493000	-	1
7 8	rosace	96490000	-	1
9 10	dispositif d'étanchéité	96487000	-	1
a	douille	96554000	-	1
	écrou	97702000	-	1
	bouchon	97258000	-	1
	joint conique 1¼"	97701000	-	1
	joint torique 38x2,5	98198000	-	1
	tube 1¼" 300 mm	53428000	-	1